

ELK. ETK

COMPACT BASIC CONTROL



ELK.ETK

- SELF-TUNING PID ALGORITHM
- INTUITIVE COLOR DISPLAY WITH TEXT MESSAGING
- UNIVERSAL PROCESS AND TC/RTD INPUTS
- MULTI-FUNCTION RAMP-DWELL/PROCESS TIMER
- SOFT START OUTPUT POWER LIMITER
- UP TO 4 CONTROL AND ALARM OUTPUTS
- LOAD CURRENT DISPLAY AND FAULT MONITOR
- UP TO 3 LOGIC INPUTS
- SERIAL MODBUS COMMUNICATIONS OPTION
- OPC BASED GRAPHICAL CONFIGURATION SOFTWARE
- IP 65 AND NEMA 4X FRONT PROTECTION
- DIGITAL RETRANSMISSION
- UP TO 5 RECIPES
- UP TO 3 ANALOG OUTPUTS
- TRANSMITTER POWER SUPPLY (ETK ONLY)

EROELECTRONIC

OVERVIEW

The new ELK (1/16th DIN) and ETK (1/8th DIN) controllers provide a new level of user convenience. Fully configurable scrolling text indication of exactly what is happening in the process.

OPERATOR INTERFACE

The new three colour display provides clear indication of process variables. The upper display shows the process value while the lower display can be set to indicate a range of parameters including, setpoint, time remaining and load current. The operator interface is fully customisable enabling any parameter to be promoted for immediate operator access. Scrolling text display messages may be up to 127 characters in length. The ETK provides additional graphic analog indication of OP power, error and heater current.

QUICK SET-UP

The Quick Start instrument set up code make configuration quick and simple. At initial power up the configuration is displayed on the lower display as an 8 character code that presets all main controller functions.

UNIVERSAL INPUTS

The Universal process and temperature input enables simple selection of standard thermocouple, RTD or mA/V process input types. Custom sensor/ input linearisations may be loaded using PC based configuration software.

TIMER FUNCTIONS

Timer functions offer the choice of: dwell timer; a delayed switch on timer or a soft start output power limit timer. A Logic input provides external control or timer function or Set point selection.

Dwell timer example

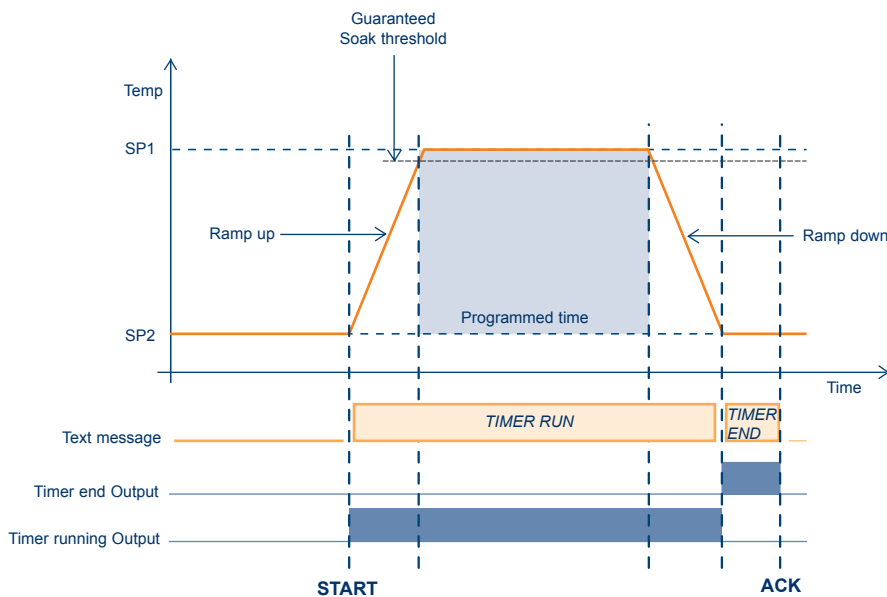

Timer operation using guaranteed soak function

Timer starts PV = SP

LOAD CURRENT TRANSFORMER INPUT

The Load Current Transformer (CT) Input monitors current flowing in the controlled load and provides immediate indication of load fault conditions. Load failure indication, heater open circuit or Solid State Relay (SSR) short circuit can each be indicated by clear scrolling operator messages and relay alarm output.

COMMUNICATION OPTIONS

The communication options provides full integration with PLC, SCADA and DCS systems using industry standard ModBus protocol. RS232 or RS485 interfaces are available.

CONFIGURATION PORT

The CPI configuration interface provides direct connection between a host PC RS232 or USB interface and the instrument without the necessity of fitting a communication option. The CPI configuration interface is a standard feature of both the ELK and ETK instruments.

CONFIGURATION WIZARD

Graphical PC based EROConfig wizard software provides a step by step guide to setting up all instrument functions, simplifying the configuration procedure. The CPI configuration interface and EROConfig wizard software enables complete instrument configurations to be copied and stored between the instrument and a host PC.

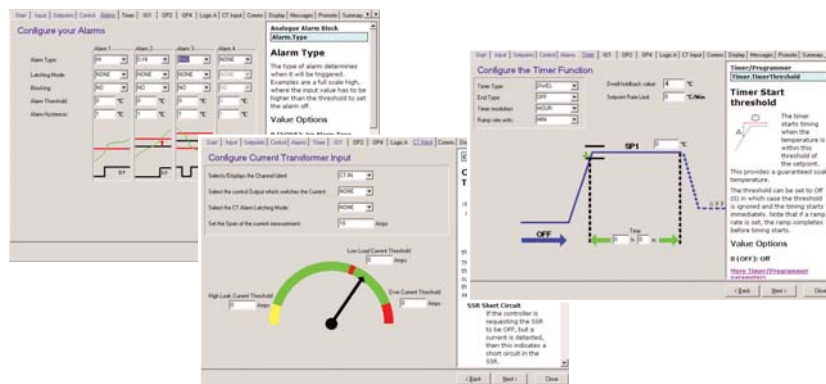

RECIPES

38 parameter values may be stored in 5 separate recipe memories, each with a customer defined name. Applications include storing multiple configurations and holding multiple ramp-dwell programs. Recipes may be selected either as a user interface option, logic input selection or communication parameter setting.

ZONE CONTROL MASTER

The master communication feature allows the ELK and ETK to transmit setpoints to slave units for multi zone control applications. Up to 32 slaves may be connected.

GENERAL SPECIFICATIONS

Sleeve:	ABS
Self-extinguishing degree:	V-0 according to UL 746C
Front protection:	IP 65 and NEMA4X for indoor location according to IEC 529, CEI 70-1 and NEMA 259-1991
Weight:	250 g max
Power supply:	- from 85 to 260V AC 50/60Hz - 24 V AC/DC
Power consumption:	5 W max
Isolation resistance:	2300 V RMS (EN 61010-1)
Sampling time:	250 ms
Accuracy:	$\pm 0.25\%$ of reading
Electromagnetic compatibility:	this instrument is marked CE
Installation category:	II
Thermal drift:	< 100 ppm/°C of the input span for TC inputs < 120 ppm/°C of the input span for RTD input
Operative temperature:	from 0 to 55 °C. (23 to 131 °F)
Storage temperature:	from -20 to +85 °C
Humidity:	from 5 % to 90% RH, non condensing

CONTROL ACTION

Standard algorithm:	ON-OFF, PID with self-tuning function, one (heat or cool) or two (heat and cool) control outputs
Local set points:	2 local set point selectable + digital remote selectable set point

ANALOG INPUTS

Thermocouples

<i>Engineering units:</i>	°C, °F, °K, % or none
<i>Cold junction:</i>	automatic compensation from 0 to 55 °C
<i>Cold junction compensation error:</i>	> 0.033 °C/°C
<i>TC type:</i>	J, K, N, T, L, R, S, B + custom

RTD

<i>Type:</i>	Pt 100 3 wires
<i>Line resistance:</i>	automatic compensation up to 20 Ω /wire
<i>Engineering units:</i>	°C, °F, °K, % or none.
<i>Burn out:</i>	the instrument detects the open condition of one or more wires and the short circuit of the sensor

Standard range table

TC type	°C	°F
B	0/1820	32/3308
L	-150/900	-238/1652
J	-150/1200	-238/2192
K	-150/1370	-238/2498
N	-150/1300	-238/2372
R	-50/1768	-58/3214
S	-50/1768	-58/3214
T	-150/400.0	-238/752

Standard range table

RTD type	°C	°F
Pt 100	-200/850	-328/1562

Linear Inputs

Type: from -10 to 80 mV,
0-20 mA, 4-20 mA
Read-out: from -1999 to 9999 with decimal point
Input impedance: > 1 M Ω for mV input
< 3 Ω for mA input

Current transformer input

Input type: from 0 to 50 mA RMS 50/60 Hz (sine wave)
Input impedance: < 20 Ω
Resolution: - 0.1 A up to 10 A
- 1 A up to 100 A

OUTPUTS**Relay**

Function: control output, alarm or event
Relay type: (OP 1,2,3) form A (OP 4) form C
Contact rating: 2 A @ 250 V AC on resistive load

Logic outputs

Function: control output, alarm or event
Logic voltage: output not isolated.
- level 1: 12 V DC @ 40 mA max
24 V DC @ 1 mA
- level 0: < 0.5 V DC

Linear mA output**Output 1 and 2**

Type: 0-20 mA or 4-20 mA not isolated

Output 3 (ETK only)

Type: 0-20 mA or 4-20 mA isolated (60V RMS)
Function: heating, cooling or retransmission
Maximum load: 500 Ω

Transmitter power supply (ETK only)

Voltage: 24 V DC
Current: max. 30 mA

ALARMS

Alarms on the measured value

Type: - process
- band
- deviation

Action: direct or reverse

Reset : automatic or manual

Mask: masked alarm or standard

Histeresys: in engineering units

Heater break-down alarm

Operative mode: - minimum alarm during the ON period
- maximum alarm during the OFF period
- over current alarm

Threshold: independent

LOGIC INPUTS

Functions: - set point select
- timer Start/stop/reset
- manual mode
- alarm acknowledge
- keyboard lock
- output power limiting
- recipe selection

Input type: contact closure voltage free

COMMUNICATION INTERFACE

Type: - factory comm. (standard)
- RS-232 (ModBus)
- RS-485 (ModBus)

TIMER FUNCTION

Type: - soak on SP1
- delay
- soft start

RECIPE FUNCTION

Number: 5 max
Parameters stored: 38 max

DIMENSIONS AND PANEL CUT - OUT (ELK)

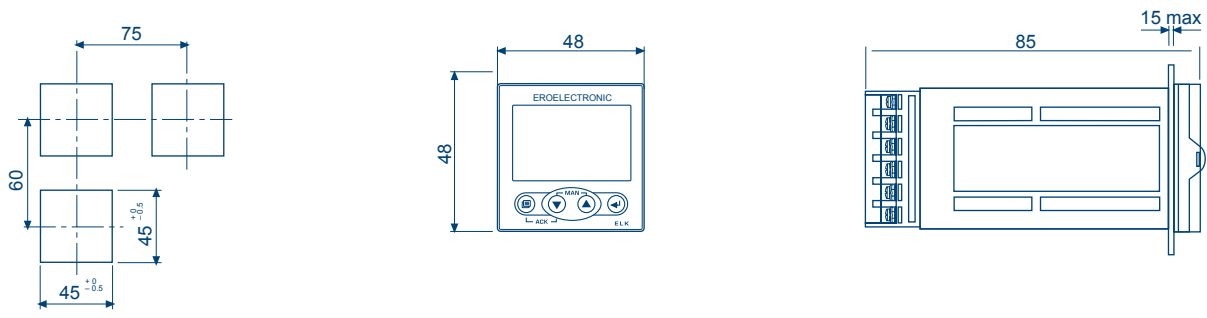

DIMENSIONS AND PANEL CUT - OUT (ETK)

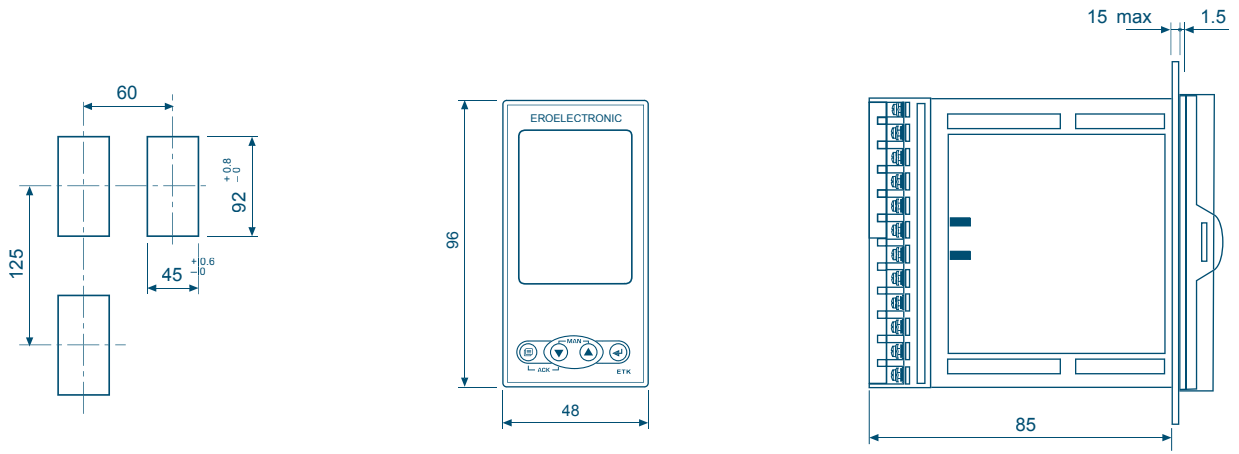

REAR TERMINAL BLOCK ELK

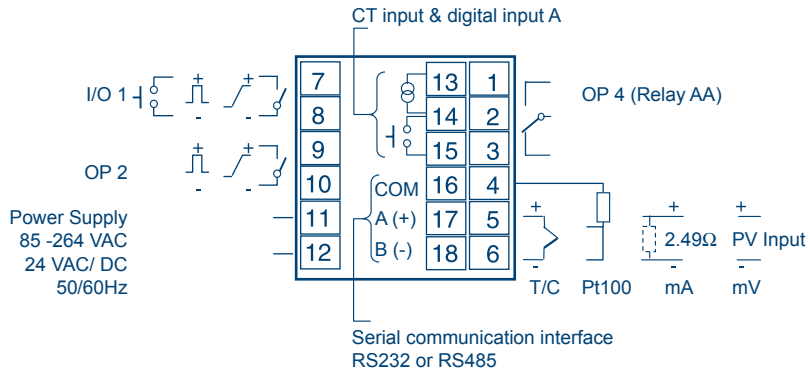

HOW TO ORDER [ELK -ETK]

MODEL	FUNCTION	PWR SUPPLY	I/O 1	OP 2	OP 3 (ETK Only)	OP 4	CT+ LOGIC IP	COMS	LANGUAGE
ELK	3 PID - ON/ OFF	3 100 - 240 V AC	1 relay (form A)	0 not fitted	0 not fitted	0 not fitted	0 not fitted	0 not fitted	E English
ETK		5 20 - 29 V AC/DC	*5 logic I/O *7 Linear out	1 relay (form A) *6 logic out (SSR) *7 Linear out	1 relay (form A) *6 logic out (SSR) 7 Linear out (isolated)	1 relay (form C)	1 CT + Logic input	1 RS 232 2 RS 485	I Italian G German F French S Spanish
	3								

Note

Available OP 1, OP 2, OP3 option combinations: 110 - 111 - 500 - 560 - 511 - 561 - 567 - 517 - 577 - 117 - 717

OP 3 options are only available on model ETK

(*) This output is not electrically isolated from the measurement input

REAR TERMINAL BLOCK ETK

