



## COMPACT THERMAL CONTROLLER



- SMART TUNE - PID CONTROL
- UNIVERSAL INPUT, 3 WIRE- TC, RTD
- 2 RELAY/ SSR OUTPUTS
- SOFT START - POWER LIMITER
- PROCESS, BAND, DEVIATION AND CONTROL FAULT ALARMS
- IP 65 AND NEMA 4X FRONT PROTECTION

PROELECTRONIC

## PRODUCT SPECIFICATIONS

<b>Case:</b>	polycarbonate case.
<b>Self extinguishing degree:</b>	V-2 according to UL 746 C.
<b>Front protection:</b>	designed and tested for IP 65 and NEMA 4X for indoor locations (when panel gasket is installed). tested accordance with IEC 529, CEI 70-1 and NEMA 250-1991 STD.
<b>Dimensions:</b>	24 x 48mm. Depth 102mm (according to DIN 43700)
<b>Weight:</b>	90g max.
<b>Power supply:</b>	- (switching mode) 100V to 240V AC 50/60Hz (-15% to + 10% of the nominal value). - 24V AC/DC ( $\pm 10\%$ of the nominal value).
<b>Power consumption:</b>	2.5VA.
<b>Common mode rejection ratio:</b>	120dB @ 50/60Hz.
<b>Normal mode rejection ratio:</b>	60dB @ 50/60Hz.
<b>EMC/Safety :</b>	this instrument is marked CE, it conforms to council directives 89/336/EEC (reference harmonized standard EN-50081-2 and EN-50082-2), 73/23/EEC and 93/68/EEC (reference harmon. standard EN61010-1).
<b>Installation category:</b>	II.
<b>Sampling time:</b>	250mSec for linear inputs 500mSec for TC or RTD inputs
<b>Accuracy:</b>	+ 0.2% f.s.v. @ 25°C (77°F) and nominal power supply voltage.
<b>Operative temperature:</b>	from 0 to +50°C (32 to 122°F).
<b>Storage temperature:</b>	from - 20 to +70°C (-4 to 158°F).
<b>Humidity:</b>	from 20% to 85% RH not condensing.

## MEASURING INPUTS

### *Thermocouples*

<b>Sensor Break:</b>	detection of the open input circuit (wires or sensor) with over range indication.
<b>Cold junction:</b>	automatic compensation for an ambient temperature between 0 and 50°C.
<b>Cold junction compensation error:</b>	0.1°C/°C.
<b>Calibration:</b>	according to IEC 584-1.

### *RTD input*

<b>Type:</b>	Pt 100 3 wire.
<b>Calibration:</b>	according to DIN 43760.
<b>Line resistance:</b>	max 20 $\Omega$ /wire with no measurable error.
<b>Sensor Break:</b>	detection of the open input circuit (wires or sensor) with over range indication. the instrument shows the short circuit indication when the sensor resistance is less than 12 $\Omega$ .

### *Linear input*

<b>Type:</b>	0-60mV. 12-60mV.
<b>Read-out:</b>	-1999 to 9999.
<b>Decimal point:</b>	programmable in any position.

## Standard range table

TC type	°C	°F
L	-100/900	-150/1650
L	-100/900	-150/1650
J	-100/1000	-0,018450185
J	-100.0/999.9	-150/8130
K	-100/1370	-150/2500
K	-100.0/999.9	-150/2500
N	-100/1400	-150/2550
R	-50/1760	-60/3200
S	-50/1760	-60/3200
T	-200/400	-330/750
T	-199.9/400.0	-330/750

## Standard range table

RTD type	°C	°F
Pt 100	-199.9/850.0	-199.9/999.9
Pt 100	-200/850	-330/1560

## CONTROL ACTION

<b>Algorithm:</b>	PID + SMART.
<b>Types:</b>	- one control output - two control outputs.
<b>Output types:</b>	relay or SSR.
<b>Output control action:</b>	proportional time.
<b>Proportional Band:</b>	from 1.0% to 100.0% of the input span. Setting a PB equal to 0, the control action becomes ON/OFF.

<b>Hysteresis (for ON/OFF control action):</b>	from 0.1% to 10.0% of the input span.
<b>Integral time:</b>	from 1 second to 20 minutes or excluded.
<b>Derivative time:</b>	from 1 second to 10 minutes or excluded.
<b>Integral preload:</b>	- for one control output, from 0 to 100% of the output ranges. - for two control outputs, from -100% to +100% of the heating/cooling output range.
<b>Main output cycle time:</b>	from 1 second to 200 seconds.
<b>Secondary output cycle time:</b>	from 1 to 200 seconds
<b>ARW action:</b>	from 10% to 200% of the proportional band.
<b>Relative secondary output gain:</b>	from 0.20 to 1.00 referred to the proportional band.
<b>Overlap / dead band:</b>	from -20% (dead band) to +50% (overlap) of the proportional band.
<b>Output limiters:</b>	- output high limit - output low limit - output max. rate of rise.

## OUTPUTS 1 & 2

### Function:

*Singularly programmable as:* - control output  
- alarm output

### Out 1 & 2 - Relay

*Relay type:* SPST.  
*Contact rating:* 3A @ 250V on resistive load.

### Out 1 & 2 - SSR

*Type:* un-isolated outputs  
- Logic level 1: 14V DC @ 20mA max. 24V DC @ 1mA.  
- Logic level 0: <0.5V DC

## ALARMS

<b>Alarm action:</b>	direct or reverse.
<b>Alarm functions:</b>	each alarm can be configured as a process alarm, band alarm or deviation alarm.
<b>Alarm reset:</b>	automatic or manual reset programmable for each alarm.
<b>Alarm masking:</b>	each alarm can be configured as a masked alarm or standard alarm.
<b>Hysteresis:</b>	programmable engineering units from 1 to 200 digits.

### Process alarm

*Operative mode:* minimum or maximum (programmable).  
*Threshold:* programmable in engineering units within the input range.

### Band alarm

*Operative mode:* inside or outside band (programmable).  
*Threshold:* low - from 0 to -1000 units.  
high - from 0 to +1000 units.

### Deviation alarm

*Operative mode:* high or low deviation (programmable).  
*Threshold:* programmable from -1000 to +1000 units.

### Loop break alarm

*Operative mode:* automatically activated when the power output reaches the programmed limits.  
*Time interval:* programmable from 1 second to 40 minutes.  
*Deviation:* programmable from 0 to 500 digits.  
*Hysteresis:* from 1 to 50% of the input span.

## HOW TO ORDER

MODEL	INPUT	OUTPUT 1 AND 2:	POWER SUPPLY	CUSTOMISATION	INTERFACE
FKS 1/32 DIN	6 TC, RTD, mV	11 Two relay outputs 61 One relay output + one SSR 66 Two SSR outputs	3 100 - 240V AC 5 24V AC/DC	00000 Std ERO Label 000B0 no label no manual 000XX Customisation	00 Standard 01 Mark 1 (*)
<b>FKS</b>	<b>6</b>				

(\*) MK1: simplified operation and configuration menu similar to LDE,LME, LMS.

## HOW TO ORDER - ACCESSORIES

INPUT ADAPTOR 0- 20mA
<b>APARTMAV00000</b>

INPUT ADAPTOR 0-10V
<b>APART10V00000</b>

INPUT ADAPTOR 0-5V
<b>APART05V00000</b>

## DIMENSIONS

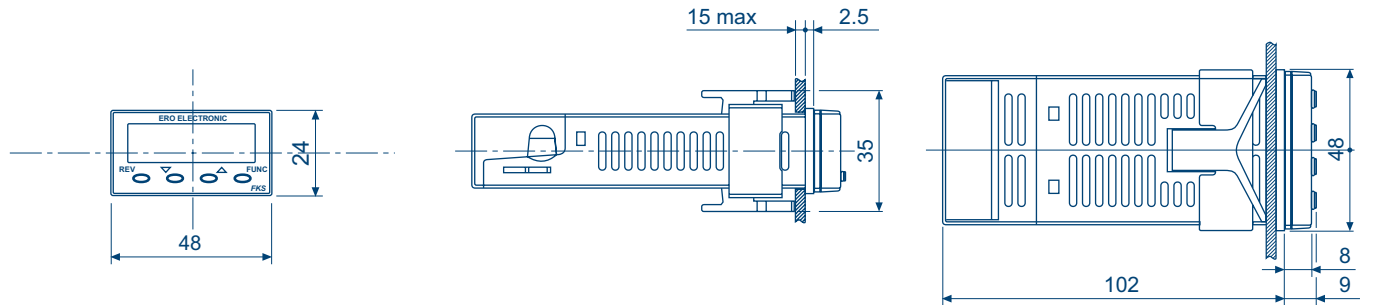

## PANEL CUT - OUT

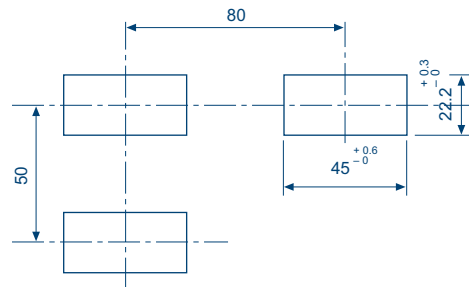

## REAR TERMINAL BLOCK

