

SSR

INDUSTRIAL SOLID STATE RELAYS



ISR.ITR.ISL
ESR.ETR

- ISR/ISR-T . ESR/ESR-T: SINGLE PHASE SOLID STATE RELAY
- ITR . ETR: 3 PHASE SOLID STATE RELAY
- ISL: LINEAR INPUT- SINGLE PHASE SOLID STATE RELAY
- RESISTIVE LOAD- ZERO CROSSING SWITCHING
- ON STATUS INDICATION
- THERMAL PROTECTION WITH STATUS INDICATION
- FRONT ACCESSIBLE IP 20 PROTECTED TERMINALS

OVERVIEW ESR-T/ ISR-T

These economical, sleek and robust single phase SSR's are designed to control resistive loads, such as heater bands and cartridge heaters, using the time proportioned DC or AC driver output from a temperature controller. Using noise-free ON-OFF zero crossing firing, these DIN rail or wall mounted units employ industrially rated reliable solid state power switching devices for optimal and reliable control in demanding industrial heating applications.

PRODUCT SPECIFICATION ESR-T/ ISR-T

Economy (triac) single phase version

Command type:	time proportioning.
Rated control voltage:	OFF state = 0 to 2V DC ON state = 4.5 to 35V DC
Input type:	Constant current (15mA).
Switching type:	zero crossing.
Load type:	resistive (min $\cos \Phi = 0,9$).
Min. holding current:	150mA RMS.
Leakage current:	20mA @ 250V AC.
Min. latching voltage:	20V.
Voltage drop on thyristors:	1,8V.
Insulation:	- between power circuit and earth: 2500V RMS for 1 minute. - between command and power circuits: 3500V RMS for 1 minute. - between command and earth: 1800V RMS for 1 minute.
Insulation resistance:	> 100M Ω at 500V DC.
Operational temperature:	from 0 to 40 °C. (from 32 to 104 °F).
Humidity:	from 20% to 85% RH non condensing.
Storage temperature:	from -20 to +70°C. (-4 to 158°F)
Protection:	IP20.
Approvals:	UL and cUL.

Amp. - V	12 - 240	18 - 240
Nominal voltage (MAX +10%)	240 V	240 V
Nominal current (@ 40°C)	12 A	18 A
Non-rep. surge current	160 A	208 A
I ² t for fusing (10 ms)	128	259
Non-rep. peak voltage	900 V	900 V
$\Delta V/\Delta T$	250 V/ μ s	250 V/ μ s
PRV	800 V	800 V
Power dissipation (I = I _{nom})	18 W	27W
Weight	510 g	510 g

PRODUCT SPECIFICATION ESR/ ISR
Single-phase version with DC input

Command type:	time proportioning.
Rated control voltage:	OFF state = 0 to 2V DC ON state = 45 to 35V DC
Input type:	Constant current (15mA).
Switching type:	zero crossing.
Load type:	resistive (min $\cos \Phi = 0,9$).
Min. holding current:	150mA RMS.
Leakage current:	20mA eff @ 600V AC
Min. latching voltage:	20V.
Voltage drop on thyristors:	1,4V.
Insulation:	- between power circuit and earth: 2500V RMS for 1 minute. - between command and power circuits: 3500 V RMS for 1 minute. - between command and earth: 1800 V RMS for 1 minute.
Insulation resistance:	> 100M Ω at 500V DC.
Operational temperature:	form 0 to 40°C. (from 32 to 104°F).
Humidity:	from 20% to 85% RH non condensing.
Storage temperature:	from -20 to +70°C. (-4 to 158°F)
Protection:	IP 20.
Approvals:	UL and cUL.

Amp. - V	25 - 400	40 - 400	60 - 400	80 - 400	25 - 600	40 - 600	60 - 600	80 - 600
Nominal voltage (MAX +10%)	400 V	400 V	400 V	400 V	600 V	600 V	600 V	600 V
Nominal current (@ 40°C)	25 A	40 A	60 A	80 A	25 A	40 A	60 A	80 A
Non-rep. surge current	380 A	900 A	1350 A	1350 A	380 A	900 A	1350 A	1350 A
I ² t for fusing (10 ms)	720	4000	9100	9100	720	4000	9100	9100
Non-rep. peak voltage	1300 V	1300 V	1300 V	1300 V	1700 V	1700 V	1700 V	1700 V
^a V/ ^a T	1000 V/ μ s	1000 V/ μ s	1000 V/ μ s	1000 V/ μ s	1000 V/ μ s	1000 V/ μ s	1000 V/ μ s	1000 V/ μ s
PRV	1200 V	1200 V	1200 V	1200 V	1600 V	1600 V	1600 V	1600 V
Power dissipation (I = I _{nom})	35 W	56 W	84 W	112 W	35 W	56 W	84 W	112 W
Weight	630 g	900 g	1400 g	2000 g	630 g	900 g	1400 g	2000 g

PRODUCT SPECIFICATION ESR AC/ ISR AC

Single-phase version with AC input

Command type:	time proportioning.
Rated control voltage:	- for 240V AC models: OFF state = 0 to 10V AC ON state = 100 to 240V AC - for 24VAC models: OFF state = 0 to 4V AC ON state = 24V AC ($\pm 15\%$)
Switching type:	zero crossing.
Load type:	resistive (min $\cos \Phi = 0,9$).
Min. holding current:	150mA RMS.
Leakage current:	max 20mA RMS @ 600V AC.
Min. latching voltage:	20V.
Voltage drop on thyristors:	1,4V.
Insulation:	- between power circuit and earth: 2500V RMS for 1 minute. - between command and power circuits: 3500V RMS for 1 minute. - between command and earth: 1800V RMS for 1 minute.
Insulation resistance:	> 100M Ω at 500V DC.
Operational temperature:	from 0 to 40°C. (from 32 to 104°F).
Humidity:	from 20% to 85% RH non condensing.
Storage temperature:	from -20 to +70°C. (-4 to 158°F)
Protection:	IP20.
Approvals:	UL and cUL.

Amp. - V	25 - 400	40 - 400	60 - 400	80 - 400	25 - 600	40 - 600	60 - 600	80 - 600
Nominal voltage (MAX +10%)	400 V	400 V	400 V	400 V	600 V	600 V	600 V	600 V
Nominal current (@ 40°C)	25 A	40 A	60 A	80 A	25 A	40 A	60 A	80 A
Non-rep. surge current	380 A	900 A	1350 A	1350 A	380 A	900 A	1350 A	1350 A
I ^t for fusing (10 ms)	720	4000	9100	9100	720	4000	9100	9100
Non-rep. peak voltage	1300 V	1300 V	1300 V	1300 V	1700 V	1700 V	1700 V	1700 V
³ V/ ³ T	1000 V/ μ s	1000 V/ μ s	1000 V/ μ s	1000 V/ μ s	1000 V/ μ s	1000 V/ μ s	1000 V/ μ s	1000 V/ μ s
PRV	1200 V	1200 V	1200 V	1200 V	1600 V	1600 V	1600 V	1600 V
Power dissipation (I = I _{nom})	35 W	56 W	84 W	112 W	35 W	56 W	84 W	112 W
Weight	630 g	900 g	1400 g	2000 g	630 g	900 g	1400 g	2000 g

OVERVIEW ETR/ ITR

These economical DIN rail or wall mount 3 phase SSR units are designed to control resistive 3 phase loads, such as heater bands and cartridge heaters, using the DC or AC SSR driver output from a temperature controller.

Using noise-free zero cross firing, the ITR / ETR / (AC) control 2 legs of the resistive 3 phase load. The third, unswitched leg is bussed through the unit for convenient connection.

PRODUCT SPECIFICATION ETR/ ITR

Three-phase version with DC input

Command type:	time proportioning.
Rated control voltage:	OFF state = 0 to 4V DC ON state = 9 to 35V DC
Input type:	Constant current (15mA).
Switching type:	zero crossing.
Load type:	resistive (min $\cos \Phi = 0,9$).
Min. holding current:	150mA RMS.
Leakage current:	20mA @ 600 V AC.
Min. latching voltage:	20V.
Voltage drop on thyristors:	1,4V.
Insulation:	- between power circuit and earth: 2500V RMS for 1 minute. - between command and power circuits: 3500V RMS for 1 minute. - between command and earth: 1800V RMS for 1 minute.
Insulation resistance:	> 100M Ω at 500 V DC.
Operational temperature:	from 0 to 40°C. (from 32 to 104°F).
Humidity:	from 20% to 85% RH non condensing.
Storage temperature:	from -20 to +70°C. (-4 to 158°F)
Protection:	IP20.
Approvals:	UL and cUL.

Amp. - V	25 - 400	40 - 400	60 - 400	25 - 600	40 - 600	60 - 600
Nominal voltage (MAX +10%)	400 V	400 V	400 V	600 V	600 V	600 V
Nominal current (@ 40°C)	25 A	40 A	60 A	25 A	40 A	60 A
Non-rep. surge current	380 A	900 A	1350 A	380 A	900 A	1350 A
I ² t for fusing (10 ms)	720	4000	9100	720	4000	9100
Non-rep. peak voltage	1300 V	1300 V	1300 V	1700 V	1700 V	1700 V
³ V/ ² T	1000 V/ μ s	1000 V/ μ s	1000 V/ μ s	1000 V/ μ s	1000 V/ μ s	1000 V/ μ s
PRV	1200 V	1200 V	1200 V	1600 V	1600 V	1600 V
Power dissipation (I = I _{nom})	70 W	112 W	168 W	70 W	112 W	168 W
Weight	1800 g	1950 g	1950 g	1800 g	1950 g	1950 g

PRODUCT SPECIFICATION ETR AC/ ITR AC

Three-phase version with AC input

Command type:	time proportioning.
Rated control voltage:	- for 240VAC models: OFF state = 0 to 10V AC ON state = 100 to 240V AC - for 24VAC models: OFF state = 0 to 3V AC ON state = 24V AC ($\pm 15\%$).
Switching type:	zero crossing.
Load type:	resistive (min $\cos \Phi = 0,9$).
Min. holding current:	150mA RMS.
Leakage current:	max 20mA RMS @ 600V AC.
Min. latching voltage:	20V.
Voltage drop on thyristors:	1,4V.
Insulation:	- between power circuit and earth: 2500V RMS for 1 minute. - between command and power circuits: 3500V RMS for 1 minute. - between command and earth: 1800V RMS for 1 minute.
Insulation resistance:	> 100M Ω at 500V DC.
Operational temperature:	from 0 to 40°C. (from 32 to 104°F).
Humidity:	from 20% to 85% RH non condensing.
Storage temperature:	from -20 to +70°C. (-4 to 158°F)
Protection:	IP20.
Approvals:	UL and cUL.

Amp. - V	25 - 400	40 - 400	60 - 400	80 - 400	25 - 600	40 - 600	60 - 600
Nominal voltage (MAX +10%)	400 V	400 V	400 V	400 V	600 V	600 V	600 V
Nominal current (@ 40°C)	25 A	40 A	60 A	80 A	25 A	40 A	60 A
Non-rep. surge current	380 A	900 A	1350 A	1350 A	380 A	900 A	1350 A
I ² t for fusing (10 ms)	720	4000	9100	9100	720	4000	9100
Non-rep. peak voltage	1300 V	1300 V	1300 V	1300 V	1700 V	1700 V	1700 V
³ V/ ² T	1000 V/ μ s	1000 V/ μ s	1000 V/ μ s	1000 V/ μ s	1000 V/ μ s	1000 V/ μ s	1000 V/ μ s
PRV	1200 V	1200 V	1200 V	1200 V	1600 V	1600 V	1600 V
Power dissipation (I = I _{nom})	70 W	112 W	168 W	112 W	70 W	112 W	168 W
Weight	1800 g	1950 g	1950 g	2000 g	1800 g	1950 g	1950 g

OVERVIEW ISL

This economical DIN rail or wall mount single phase SSR unit is designed to control resistive loads, such as heater bands and cartridge heaters, using the linear 4-20mA proportional output from a temperature controller. Using noise-free zero cross firing, the robust ISL comes with a Fast Cycle control option for heavy thermal loads requiring less frequent switching and a Single cycle control option for lighter thermal loads needing faster switching or more precise control.

PRODUCT SPECIFICATION ISL

Input type:	4-20 mA linear
Input impedance:	300Ω
Operative mode:	3 programmable operative modes: - fast cycle - slow cycle - single cycle
Switching type:	zero crossing full wave
Load type:	resistive
Min. holding current:	50mA RMS
Leakage current:	10mA RMS
Min. latching voltage:	20V
Voltage drop on SCR:	1,2V
Insulation:	- between power circuit and earth: 3000V RMS for 1 second. - between command and power circuits: 3000V _{pk}
Insulation resistance:	> 1 MΩ at 500V DC for ISL 400V > 2 MΩ at 500V DC for ISL 600V
Operational temperature:	from 0 to 50° (from 32 to 122°F)
Humidity:	from 20% to 85% RH non condensing
Storage temperature:	from -20 to + 70 °C (-4 to 158°F)
Protection:	IP20
Mounting:	rear-of-board on wall or omega DIN rail
Terminals:	screw terminals with front access
Approval:	UL and cUL

Amp. - V	25 - 400	35 - 400	45 - 400	60 - 400	80 - 400	25 - 600	35 - 600	45 - 600	60 - 600	80 - 600
Nominal voltage (MAX +10%)	400V	400 V	400 V	400 V	400 V	600 V	600 V	600 V	600 V	600
Nominal current (@ 50°C)	25 A	35 A	45 A	60 A	80 A	25 A	35 A	45 A	60 A	80 A
Non-rep. surge current	280A	400 A	400 A	1200 A	1200 A	280 A	400 A	400 A	1200 A	1200 A
I ² t for fusing (10 ms)	550	860	860	10180	10180	550	860	860	10180	10180
Non-rep. peak voltage	1300 V	1300 V	1300 V	1300 V	1300 V	1600 V	1600 V	1600 V	1600 V	1600 V
DV/Dt	500V/ms	500V/ms	500V/ms	500V/ms	500V/ms	1000V/ms	1000V/ms	1000V/ms	1000V/ms	1000V/ms
PRV	1200 V	1200 V	1200 V	1200 V	1200 V	1600 V	1600 V	1600 V	1600 V	1600 V
Total power dissipation (I = I _{nom})	30 W	45 W	55 W	75 W	100 W	30 W	45 W	55 W	75 W	100 W
Weight	630g	630 g	800 g	1100 g	2000 g	630 g	630 g	800 g	1100 g	2000 g

WHAT IS A SOLID STATE RELAY OR SCR POWER CONTROLLER?

A Solid State Relay (SSR), or SCR Power Controller uses semiconductor devices to switch AC power ON and OFF to control the electrical power delivered to heating elements. ERO electronic incorporate solid state power devices, such as SCR's or triacs, together with control electronics and a heatsink that dissipates the heat generated by the power device.

Power Controllers offer a reliable long term alternative to electromechanical devices. Power Controllers generally provide improved control, easy servicing and a reduction of downtime and maintenance. They are the best means of controlling electrical power.

CONTROL MODES

ERO electronic controllers are available in two basic control of firing modes: ON-Off or Fast Cycle/ Single Cycle.

ON-OFF

In the ON-OFF control mode, the output of the contactor turns ON only when the input is turned on and the supply voltage is at a zero crossing point. If the input is turned on at a non-zero point, the contactor will simply wait for the next zero point to turn ON. Unlike a mechanical relay, the power controller with ON-OFF control eliminates electrical switching disturbances and audible noise. ON-OFF control is available in all ERO electronic Power Controllers except the ISL.

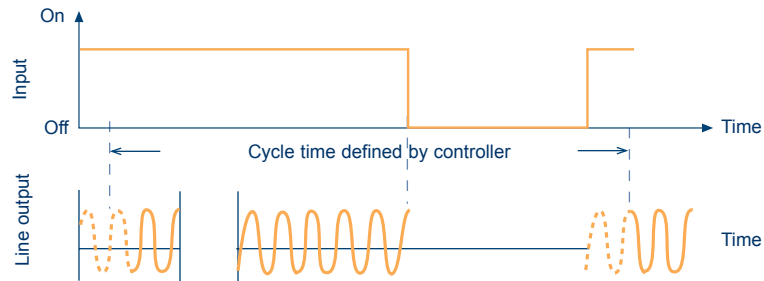

FAST CYCLE

In the Fast Cycle control mode, the controller also only turns ON at a zero crossing point, but it uses a fixed 100 cycle time base for control. For example, 50 cycles ON and 50 cycles OFF results in a 50% output. Fast Cycle control is best for loads that need slower, less frequent switching (resistive loads).

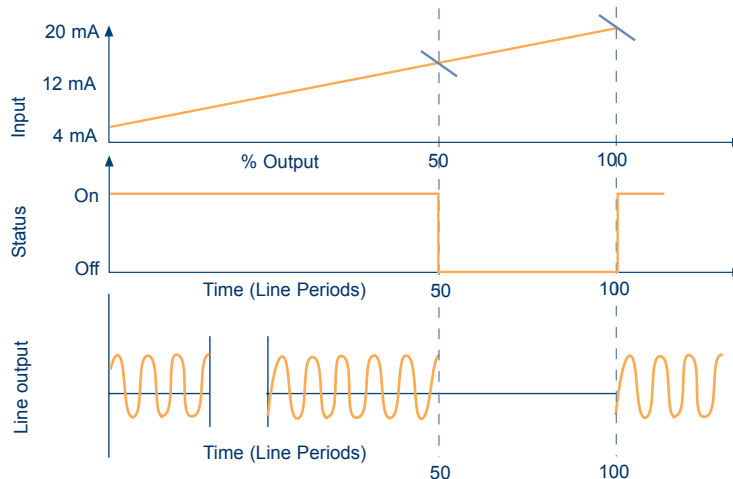

SINGLE CYCLE

In the Single Cycle control mode, the controller once again only turns ON at a zero crossing point, but uses a variable time base (ON time plus OFF time) for control. Based on the command level, the time base is kept at a minimum, which improves control compared to the Fast Cycle control mode. For example, one cycle ON and one cycle OFF results in a 50% output. Three cycles ON and one cycle OFF in a 75% output. Single Cycle control is best for loads that require faster, more precise control (low thermal inertia loads).

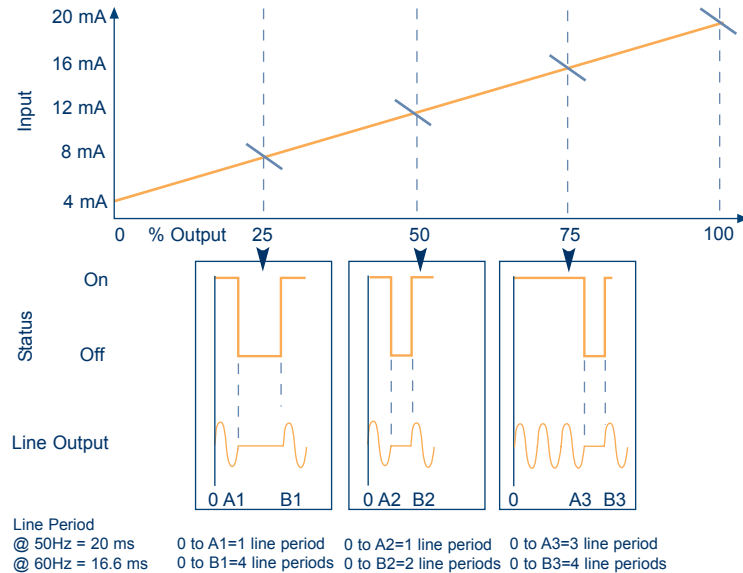

THERMAL PROTECTION

Temperature ratings for Solid State Contractors and SCR Power Controllers are listed in the specifications at continuous operation at 100% output and 100% duty cycle. These conditions assume that all recommended instructions for mounting and cooling airflow access are followed. Power Controllers are designed to work up to a specific temperature. If that temperature is exceeded, the unit is likely to be damaged. Thermal protection can prevent excessive temperatures from damaging the power unit. When the SSR junction temperature reaches 125°C (275°F), the inhibit and the OH (overheat) LED indicator is illuminated. Once the temperature is within acceptable limits, the command signal is again enabled and the OH LED turns off.

AGENCY APPROVAL

All Electroelectronic SSR models have approval ratings for CE, UL and cUL.

INSTALLATION

These Power Controllers must be installed in accordance with the recommendations expressed in the installation guide supplied with each unit, and also in accordance with local wiring regulations. It is important to note that each controlled phase in an SCR generates a heat loss calculated at approximately 1.2 watts per amp per phase (1.8 for the ISR / ESRT). Adequate ventilation or forced cooling must be provided to maintain ambient conditions inside the control panel enclosures within the operating specification.

FUSE PROTECTION

SCR Power Controllers and Solid State Relays require high speed fuses to protect the power device against short circuit currents resulting from load or wiring faults. High speed fuses must be externally mounted. Consult the catalogue for recommended fusing for our power controllers. The high speed fuse does not provide protection to the load or to the branch of the circuit against sustained medium scale overloads, and it is therefore necessary to fit a standard circuit protection fuse (HCR fuse or circuit breaker) in the supply lines to the Power Controller.

DIMENSIONS and PANEL CUT - OUT

ESR/ T [12][18][25]A

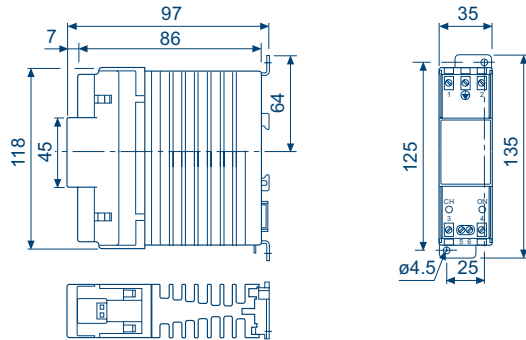

ISR/ T [12][18]A
ISL [25][35]A

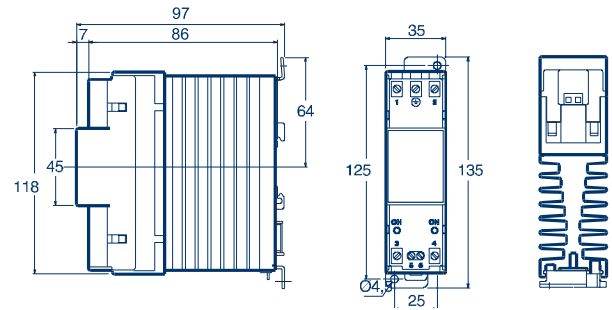

ESR 40A

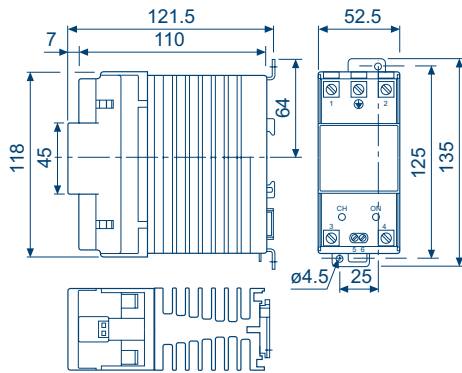

ISR - ISL [45]A

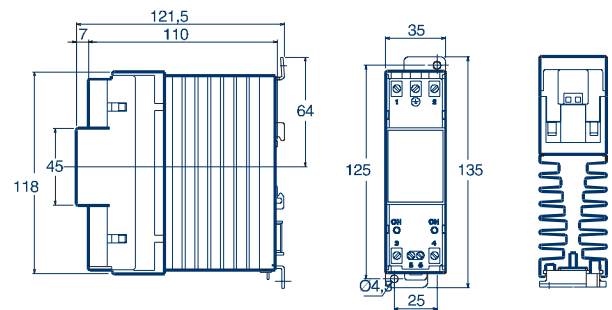

ESR 60A

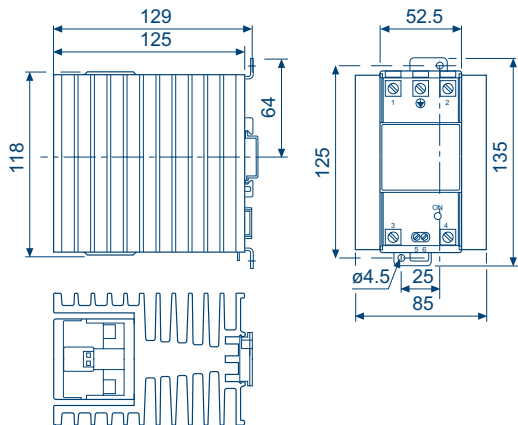

ISR - ISL [60]A

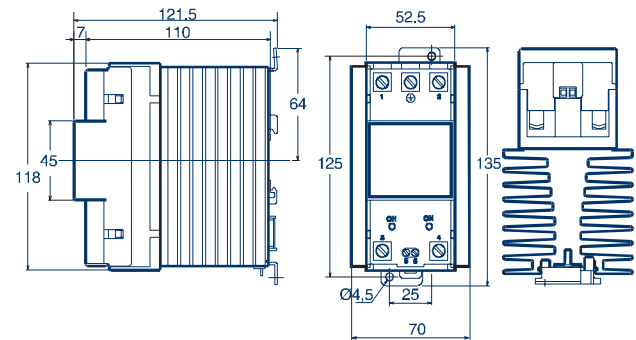

ESR 80A

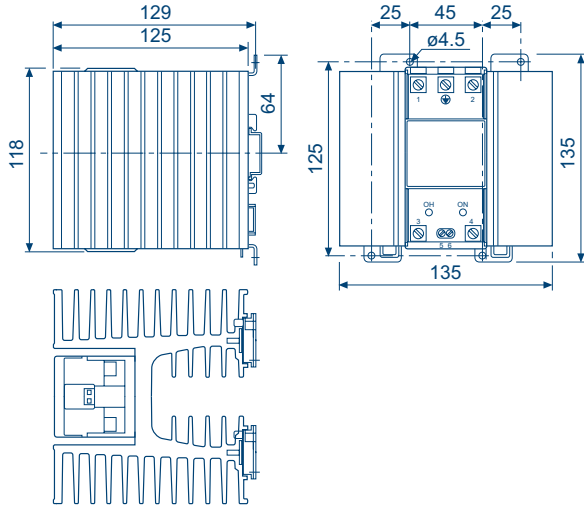

ISR - ISL [80]A

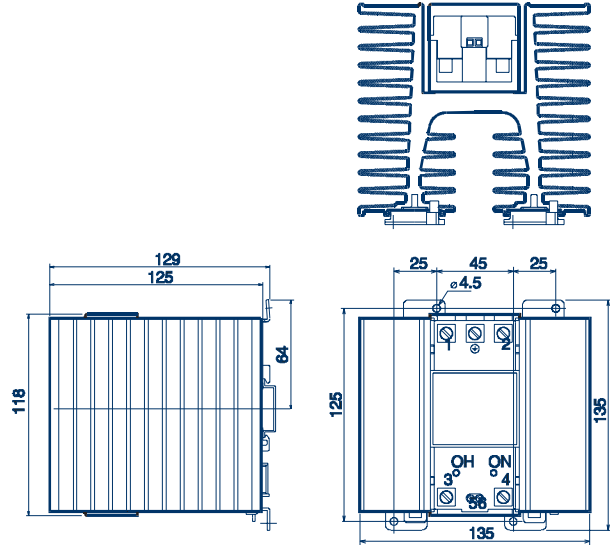

ETR 25A

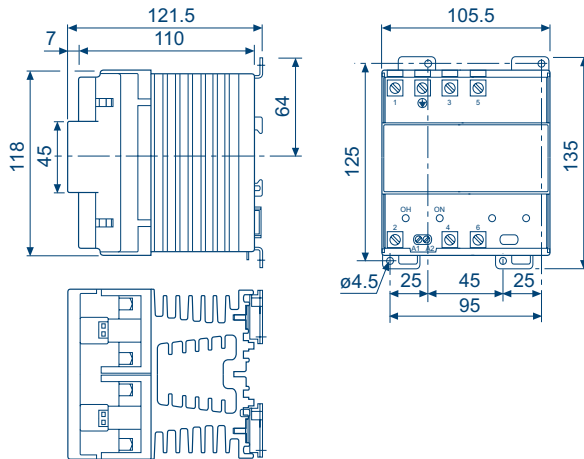

ITR [20][40]A

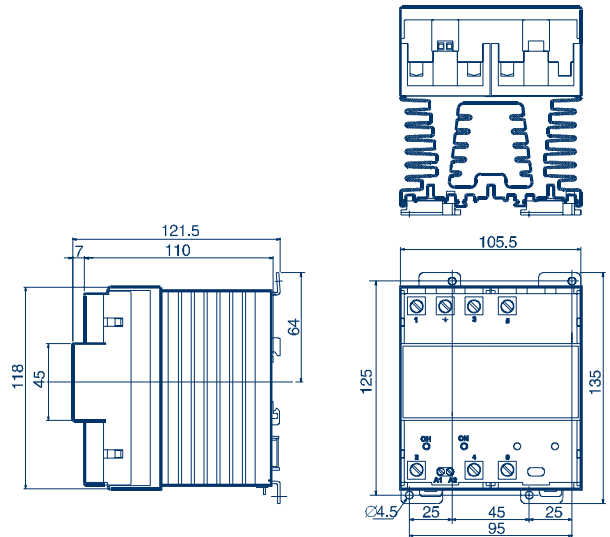

ETR 40/60A

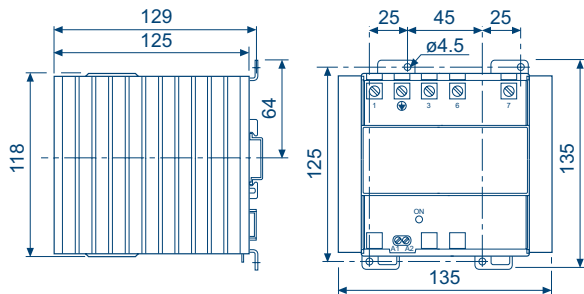

ISR.ITR.ISL.ESR.ETR

HOW TO ORDER ESR T/ ISR T

MODEL	NOMINAL CURRENT	NOMINAL VOLTAGE	OPTION
ESR T SSR with TRAIAC	12 12A	240 240V rms	0 no option
ISR T SSR with TRAIAC	18 18A		
		240	0

HOW TO ORDER ESR/ ISR

MODEL	NOMINAL CURRENT	NOMINAL VOLTAGE	OPTION
ESR single-phase with DC input	025 25A 060 60A	400 400V rms	0 no option
ISR single-phase with DC input	040 40A 080 80A	600 600V rms	1 Over-heating alarm

HOW TO ORDER ESR AC/ ISR AC

MODEL	NOMINAL CURRENT	NOMINAL VOLTAGE	RATED CONTROL VOLTAGE
ESRAC single-phase with AC input	25 25A 60 60A	40 400 V eff.	1 100-240V rms
ISRAC single-phase with AC input	40 40A 80 80A	60 600 V eff.	2 24V rms

HOW TO ORDER ETR/ ITR

MODEL	NOMINAL CURRENT	NOMINAL VOLTAGE	RATED CONTROL VOLTAGE
ETR Tree-phase with DC input	025 2 x 25A 060 2 x 60A	400 400V rms	0 no option
ITR Tree-phase with DC input	040 2 x 40A	600 600V rms	1 Over-heating alarm

HOW TO ORDER ETR AC/ ITR AC

MODEL	NOMINAL CURRENT	NOMINAL VOLTAGE	RATED CONTROL VOLTAGE
ETR AC Tree-phase with AC input	25 2 x 25A 60 2 x 60A	40 400V rms	1 100-240V AC
ITR AC Tree-phase with AC input	40 2 x 40A	60 600V rms	2 24V AC