



170.IU0.CON.VA0 0,3.11-98



USER MANUAL

**CONV-X  
MK1**



A Siebe Group Product



**INDEX**

**1 - GENERAL INFORMATION**

1.1 - INTRODUCTION ..... 4  
1.2 - PRODUCT SPECIFICATIONS ..... 4

**2 - OPERATIVE MODES**

2.1 - OPERATIVE MODE A -  
interface between RS-232C and RS-422A ..... 5  
2.2 - OPERATIVE MODE B -  
interface between RS-232C and RS-485 with  
external transmission/reception control ..... 6  
2.3 - OPERATIVE MODE C -  
interface between RS-232C and RS-485 with  
automatic transmission/reception control ..... 6

**3 - HARDWARE SETTINGS**

**4 - INSTALLATION**

4.1 - MOUNTING ..... 9  
4.2 - WIRING GUIDE LINE ..... 9  
4.3 - POWER LINE ..... 10  
4.4 - MODE A - RS-232C - RS-422A  
WIRING GUIDE LINES ..... 11

4.5 - MODE B - RS-232C - RS-485  
WITH EXTERNAL LINE CONTROL -  
WIRING GUIDE LINE ..... 13  
4.6 - MODE C - RS-232C - RS-485  
WITH AUTOMATIC LINE CONTROL -  
WIRING GUIDE LINE ..... 15

**5 - GENERAL ASSEMBLY ..... 17**

**6 - CODING ..... 17**

**7 - LABELS ..... 18**

**APPENDIX A ..... 19**

## 1 - GENERAL INFORMATION

### 1.1 INTRODUCTION

The CONV-X is a micro processor based serial interface converter developed for a smart field problems solution. The flexibility is the most important feature of this converter and it is proved by the 3 different operative modes:

- A) conversion from RS-232C to RS-422A assuring the complete isolation between the two serial interfaces and the correct level signals for both interfaces.
- B) conversion from RS-232C to RS-485 with external handling of the line inversion (by RTS) assuring the compatibilities with other interface adapters.
- C) conversion from RS-232C to RS-485 with automatic handling of the line inversion. This solution guaranty not only the isolation and the correct level signals for both interfaces, but also a smart handling of the line inversion raising the software developer from all problems of line administration.

The construction in accordance to the IEC and EIA standards and the full isolation between all parts offer the widest range of possible application of this serial interface converter.

## 1.2 - PRODUCT SPECIFICATIONS

### GENERAL SPECIFICATIONS

**Case:** PC/ABS black colour; self-extinguishing degree : V-0 according to UL 96.

**Protection :** IP 20 according to IEC 529 and CEI 70-1.

**Isolation:** Optical isolation between RS-232C and RS-485 (or RS-422A) ; galvanical isolation between power supply and digital circuits.

**Installation:** behind the board on DIN 46227/3 omega rail. Instrument removable from case by screwdriver help.

**Plug in construction:** PC boards are assembled by snap in action for easy inspection and replacement of all boards.

**Terminal block:** with screw terminals (screw M3 for cable from AWG 22 to AWG 14) with identification labels, connection diagrams and safety cover.

**Dimensions:** DIN 43700 48 x 96 mm, depth 125 mm.

**Weight:** 300 g max.

**Power supply:** 100 to 240V AC (switching type) or 24 AC/DC 50/60Hz.

**Power supply variations:** from -15 % to +10% of the nominal value.

**Power consumption:** 4 VA max.  
**Isolation resistance:** > 100 MΩ according to IEC 1010-1.  
**Dielectric strength:** 1500 V r.m.s. continuous, according to IEC 1010-1.  
**Ambient temperature:** 0 to +50 °C.  
**Storage temperature:** -20 to +70 °C.  
**Humidity:** from 20% to 85% RH, non condensing.  
**Protections:** WATCH DOG circuit for automatic restart.

#### **SERIAL INTERFACES**

##### **Communication type:**

Mode A: bi-directional full-duplex;  
Mode B and C: bi-directional half-duplex.

##### **Baud rate:**

Mode A and B: free with max. 76800 baud;  
Mode C: 150, 300, 600, 1200, 2400, 4800, 9600,  
19200, baud selectable by internal dip  
switch.

**Line length:** 15 m max for RS-232C;  
1200 m max (@19200 baud) for RS-422A and  
RS-485.

##### **Word length:**

Mode A and B: free  
Mode C: 7 or 8 bit, with or without parity, 1 or 2 stop  
bit selectable by internal dip switch.

## **2 - OPERATIVE MODES**

The CONV-X offers 3 different operative mode:

### **2.1 - OPERATIVE MODE A - Interface between RS-232C and RS-422A**

In this mode the CONV-X assures the complete isolation between the two serial interfaces and the correct level signals for both interfaces.

In this operative mode the communication may be full-duplex and the communication protocol have no limit for word length and baud rate (max. 19200 baud).

**NOTE:** using two CONV-X set in mode A, it is possible to connect two RS-232C interface on a long distance (the first instrument convert from an RS-232C to an RS-422A and, after max. 1200 m, the second one convert from RS-422A to RS-232C).

## **2.2 - OPERATIVE MODE B - interface between RS-232C and RS-485 with external transmission/reception control**

In this mode the CONV-X convert a full-duplex standard communication interface (RS-232C) into a half-duplex standard communication interface (RS-485).

In this situation two elements are critical:

- 1) the communication protocol must be half-duplex;
- 2) it is necessary to manage the direction of the informations (from master to slave or viceversa).

This manage must assure the line switching after the complete transfer of the last data only and before the start of the relative reply.

In this operative mode too, the communication protocol have no limit for word length and baud rate (max. 19200 baud) but the line switching management may be very difficult for expert software developer also.

The line switching is made by a software administration of a logic signal (usually RTS) whose status defined the transmission direction (from RS-232C to RS-485 or viceversa).

When the RTS signal have a binary 1 state ( $3V < V_{RTS} < 25V$ ) the data came from RS-485 to RS-232C.

When the RTS signal have a binary 0 state ( $-25V < V_{RTS} < -3V$ ) the data came from RS-232C to RS-485.

It is possible to revert the ratio between signal status and transmission direction by an internal jumper.

## **2.3 - OPERATIVE MODE C - interface between RS-232C and RS-485 with automatic transmission/reception control**

In this mode the CONV-X assures a smart conversion of a full-duplex standard communication interface (RS-232C) into a half-duplex standard communication interface (RS-485) offering to the user a transparent management of the data direction.

In this condition it is only necessary that the communication protocol is a half-duplex type.

The instrument guaranty an automatic and correct line switching and relieve the user from all problems of line management.

In this operative mode, the converter needs to know the word length and the baud rate used by communication protocol.

### 3 - HARDWARE SETTINGS

Before to install the instrument, it is necessary to perform the following settings.

A brief description of the instrument extraction and cards removal are shown in paragraph 5 "GENERAL ASSEMBLY".

Set the desired operative mode according to the following table

MODE	FUNCTION	J101	J102
A	RS-232C into RS-422A	1 - 2	1 - 2
B	RS-232C into RS-485 with external line control	2 - 3	1 - 2
C	RS-232C into RS-485 with automatic line handling	1 - 2	2 - 3
	RESERVED	2 - 3	2 - 3

When mode A is selected, no other setting are required.

Mode B requires to define the sense of the external line control signal (RTS) in relation with the transmission direction.

The possible solutions are shown in the following table:

FUNCTION	J103
A positive signal on RTS selects the transmission from RS-232C to RS-485.	1 - 2
A positive signal on RTS selects the transmission from RS-485 to RS-232C	2 - 3

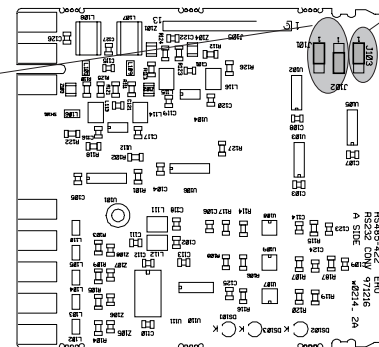

When mode C (automatic line handling) is selected it is necessary to set:

1) the baud rate; according to the following table:

Baud rate	SW1	SW2	SW3	SW4
150	ON	ON	ON	ON
300	ON	ON	ON	OFF
600	ON	ON	OFF	ON
1200	ON	ON	OFF	OFF
2400	ON	OFF	ON	ON
4800	ON	OFF	ON	OFF
9600	ON	OFF	OFF	ON
19200	ON	OFF	OFF	OFF
reserved	OFF	ON	ON	ON
reserved	OFF	ON	ON	OFF
reserved	OFF	ON	OFF	ON

2) the word length; according to the following table:

FORMAT (in bit)	SW7	SW8
1 start + 7 data + 1 stop	ON	ON
1 start + 7 data + 1 parity + 1 stop	ON	OFF
1 start + 7 data + 2 stop	ON	OFF
1 start + 8 data + 1 stop	ON	OFF
1 start + 7 data + 1 parity + 2 stop	OFF	ON
1 start + 8 data + 2 stop	OFF	ON
1 start + 8 data + 1 parity + 1 stop	OFF	ON
1 start + 8 data + 1 parity + 2 stop	OFF	OFF

The dip switches 5 and 6 must be in ON condition

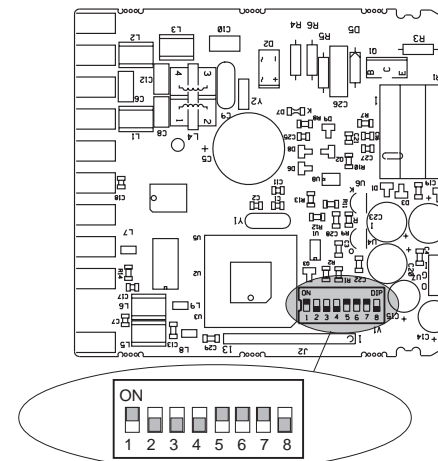

NOTE: the instrument detects the dip switch setting at instrument switching on only. After a modification of the dip switch set, switch off the converter and then switch it on again.

## 4 - INSTALLATION

### 4.1 MOUNTING

Select a mounting location where there is minimum vibration and the ambient temperature must be between 0 and 50 °C. The instrument can be mounted on a DIN 46277/3 omega rail.

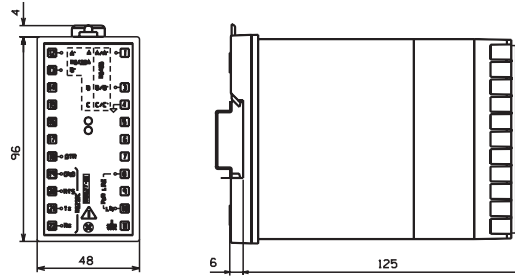
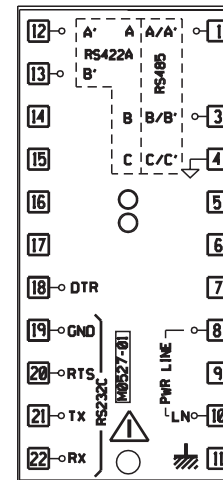

Fig. 4.1 DIMENSION

### 4.2 - WIRING GUIDE LINES

Connections are to be made with the converter housing installed in its proper location.



### 4.3 - POWER LINE

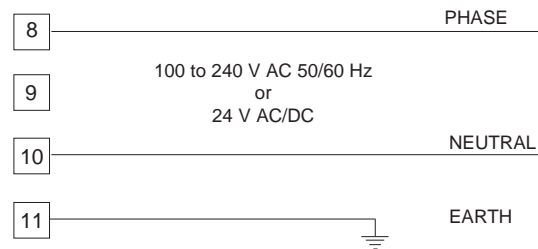

Fig. 4.2 POWER LINE WIRING

#### NOTES:

- 1) Before connecting the instrument to the power line, make sure that line voltage corresponds to the description on the identification label.
- 2) To avoid electrical shock, connect power line at the end of the wiring procedure.
- 3) For supply connections use No 16 AWG or larger wires rated for at least 75 °C.
- 4) Use copper conductors only.

- 5) Don't run input wires together with power cables.
- 6) For 24 V DC the polarity is a not care condition.
- 7) The power supply input is not fuse protected.  
Please, provide a fuse, rated T- 0.5 A - 250 VAC, externally. When fuse is damaged, it is advisable to verify the power supply circuit, so that it is necessary to send back the instrument to your supplier.
- 8) The safety requirements for Permanently Connected Equipment say:
  - a switch or circuit-breaker shall be included in the building installation;
  - it shall be in close proximity to the equipment and within easy reach of the operator;
  - it shall be marked as the disconnecting device for the equipment.**NOTE:** a single switch or circuit-breaker can drive more than one instrument.
- 9) When a neutral line is present please connect it to the 10 terminal.

#### 4.4 - MODE A - RS-232C - RS-422A WIRING GUIDE LINES

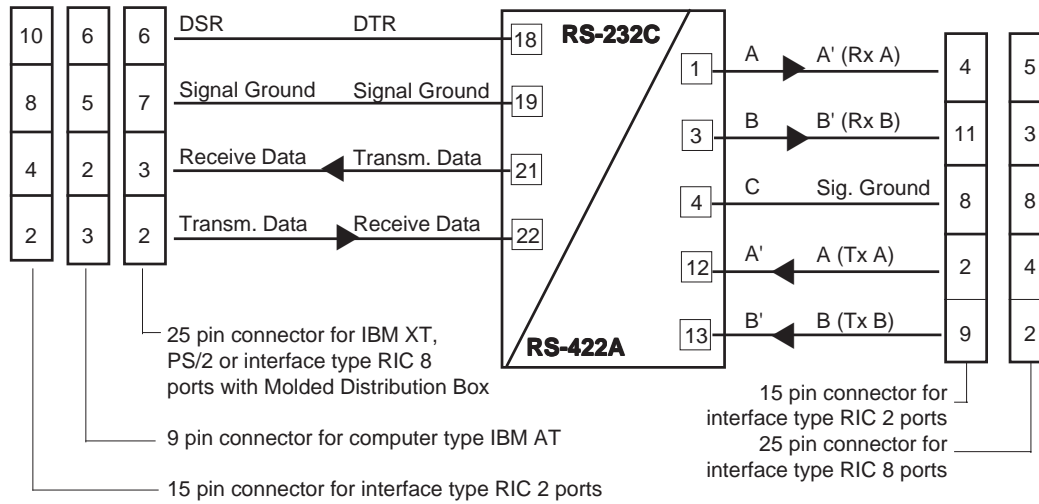

**NOTE :** 1) The cable length for RS-422A serial interface must not exceed 1.2 km at 19200 baud.

2) The RS-422A standard interface allows to interconnect 2 devices only.

3) The cable length for RS-232C serial interface must not exceed 15 m at 19200 baud.

4) The RS-232C standard interface allows to interconnect 2 devices only.

5) Do not run the data lines together with power cable.

6) If shielded cable is used, it should be grounded at one point only.

7) The following report describes the signal sense of the voltage appearing across the interconnection cable as defined by EIA for RS-485 and RS-422A.

a) The "A" terminal of the generator shall be negative with respect to the "B" terminal for a binary 1 (MARK or OFF) state.

b) The "A" terminal of the generator shall be positive with respect to the "B" terminal for a binary 0 (SPACE or ON) state.

**4.5 - MODE B - RS-232C - RS-485 WITH EXTERNAL LINE CONTROL - WIRING GUIDE LINES**

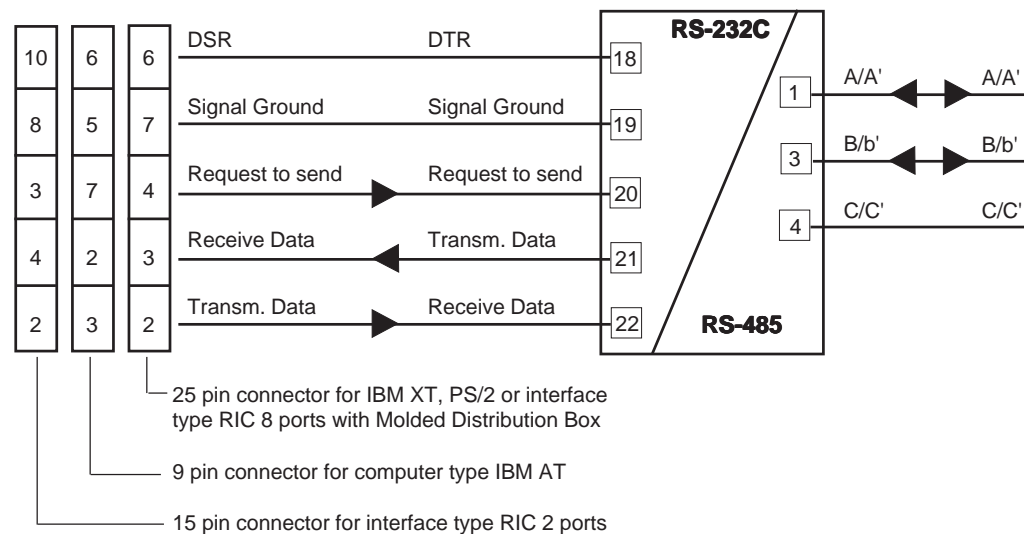



- 
- NOTE :**
- 1) The cable length for RS-485 serial interface must not exceed 1.2 km at 19200 baud.
  - 2) The RS-485 standard interface allows to interconnect up to 32 devices.
  - 3) The cable length for RS-232C serial interface must not exceed 15 m at 19200 baud.
  - 4) The RS-232C standard interface allows to interconnect 2 devices only.
  - 5) Do not run the data lines together with power cable.
  - 6) If shielded cable is used, it should be grounded at one point only.

**WARNING**

The RS-485 standard is a half-duplex communication interface. The communication protocol must be half-duplex when this type of interface is used.

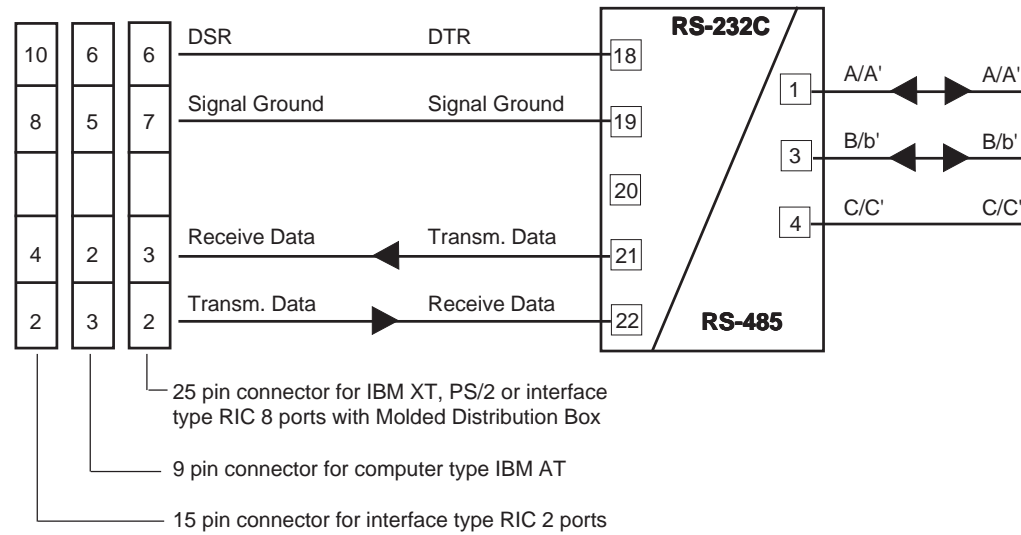
**4.6 - MODE C - RS-232C - RS-485 WITH AUTOMATIC LINE CONTROL - WIRING GUIDE LINES**



- 
- NOTE :** 1) The cable length for RS-485 serial interface must not exceed 1.2 km at 19200 baud.  
2) The RS-485 standard interface allows to interconnect up to 32 devices.  
3) The cable length for RS-232C serial interface must not exceed 15 m at 19200 baud.  
4) The RS-232C standard interface allows to interconnect 2 devices only.  
5) Do not run the data lines together with power cable.  
6) If shielded cable is used, it should be grounded at one point only.

**WARNING**

The RS-485 standard is a half-duplex communication interface. The communication protocol must be half-duplex when this type of interface is used. When the mode C is used, the RTS signal (Request to Send) will be ignored.

## 5 - GENERAL ASSEMBLY

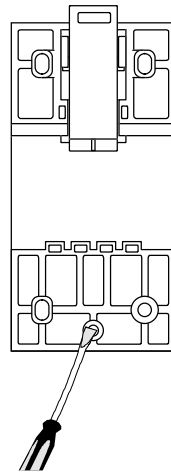

Fig. 5.1 INSTRUMENT EXTRACTION

## 6 - CODING

**MODEL**  
CONV-X MK1= smart converter

**POWER SUPPLY**  
3 = 100 / 240 V AC  
5 = 24 V AC/DC

CONV-X MK1







## 7.2 ABRIDGED LABELS

Two abridged labels are provided to allow the instrument parts to be identified.  
They are located : (a) on the bottom of the card; (b) internally on the bottom front of the housing.  
The abridged labels contain the Model Number and the Serial Number only.

## APPENDIX A

IBM XT, AT, PS/2 and RIC are registered trade marks of the International Business Machines.

The RIC (Real time Input/output Coprocessor) is an hardware board of the IBM and it is available in RS-232C or RS-422A versions.





**Ero Electronic s.r.l.**

Via Nino Bixio, 47/49  
20026 Novate Milanese (Milano)  
Italy

Tel. (+39) 02354781  
Fax. (+39) 023546625

**A Siebe Group Company**

**Representatives**

**CHINA**

TIANJIN VEGA COMPANY Ltd  
95 Zhi Cheng Road  
Hebei District  
300232 Tianjin PRC  
Tel.: 022-26273296  
Fax.: 022-26273297

**U.S.A.**

AMERICAN ERO ELECTRONIC CORP.  
365 Bateman Circle  
P.O. Box 3608  
BARRINGTON ILL. 60010  
Tel: 847-382-0881  
Fax: 847-382-0240

**UNITED KINGDOM / EIRE**

EUKERO CONTROLS LTD  
Unit 1 Waterside Business Centre  
Railhead Road - Isleworth  
Middlesex TW7 7BY  
Tel.: 0181-5684664  
Fax: 0181-5684115

**Branch Offices**

**BENELUX**

ERO ELECTRONIC BENELUX S.A./N.V.  
Rue du Val-Notre-Dame, 384  
4520 MOHA (Wanze)  
Tel.: 085-274080  
Fax: 085-274081

**GERMANY**

ERO ELECTRONIC GmbH  
Quarzeweg 1a  
D-65604 Elz  
Tel.: 06431-95680  
Fax: 06431-57493

**BRAZIL**

ERO ELECTRONIC DO BRASIL  
Industria e Comercio Ltda  
Rua Garibaldi, 659 - Conj. 202  
90035-050 Porto Alegre - RS - Brasil  
Tel.: 051-2214888  
Fax.: 051-2214734

**SOUTH AFRICA**

ERO ELECTRONIC S.A.  
P.O. Box 43112  
2042 INDUSTRIA  
Tel.: 011-4742278  
Fax: 011-4749404

**SWITZERLAND**

ERO ELECTRONIC AG  
Kemptalstrasse 27/A  
8320 FEHRALTORF  
Tel.: 01-9542220  
Fax: 01-9543284

**FRANCE**

ERO ELECTRONIC Sarl  
ZAC du Chêne  
34, rue du 35ème Régiment d'Aviation  
69673 BRON Cedex  
Tel.: 0478267979  
Fax: 0478267800

**Factories**

**ITALY**

ERO ELECTRONIC S.r.l.  
Via E. Mattei, 21  
28100 Novara

**MALTA**

ERO ELECTRONIC (Malta) Limited  
Tübingen Centre  
F17, Mosta Technopark  
Mosta MST 02